

## Using the Si9145 PWM Converter with the Pentium™ P55 and P6 Microprocessors

Chae Lee

### Powering the P55 and P6

When powering a Pentium microprocessor, a wide bandwidth converter is needed to minimize the overall output capacitance both at the power supply and at the microprocessor. While this was certainly true of the P54C-VRE, the new P55 and P6 microprocessors are pushing the limits of switching power supplies even further. The transient amplitude of the P55 and P6 is specified at approximately 7.75 A and 9.5 A, respectively, within a 350-ns window. Although the regulation limit has been widened to 4% (P55) and 5% (P6) from 2.13% (P54), the implied headroom has increased only slightly since output voltage has dropped from 3.525 V (P54) to 2.5 V (P55) and 2.9 V (P6).

Although the new requirements are demanding, they are easily met by Siliconix' Si9145 PWM controller. The Si9145 is capable of switching at approximately 400 kHz, with a 25-MHz error amplifier to generate the 100-kHz closed-loop converter bandwidth. With this 100-kHz converter bandwidth translating to a 5- $\mu$ s response time from the switching power supply, only a few external components are needed to meet the transient requirements of the new Pentium devices: three 330- $\mu$ F Oscon capacitors and the same decoupling capacitance at the microprocessor as used with P54 family.

The Si9145 PWM controller IC provides the fastest switching and response time of any such solution available today. Its high switching frequency allows the use of smaller inductors and output capacitors for a given ripple voltage. A wide bandwidth converter allows designers to reduce the number of output capacitors required to meet the transient response of P55 and P6 microprocessors. Together, these features make the Si9145 the most cost-effective switching power supply solution presently on the market.

### SPICE Simulations for P55 and P6 Microprocessors

The worst-case load transients specified by Intel for the P55 and P6 were simulated using Intusoft SPICE simulation software. The decoupling capacitance and parasitic parameter characteristics at the microprocessor were modeled exactly as specified for the P54 processor, using six 100-F tantalum capacitors and 25 1-F ceramic capacitors. The capacitance at the output of the power supply was modeled with three 330-F Oscon capacitors. Simulation results for the P55 (7.75 A) and the P6 (9.5 A) are shown in Figures 1 and 2. The rise time of the step load for both processors was set at 350 ns, as specified by Intel.

The instantaneous drop in the microprocessor's voltage shown in both figures is controlled by the ESR value of total decoupling and power supply output capacitance. As is evident, the larger the ESR, the greater the voltage drop. For this reason, the total ESR must be minimized to ensure that the regulation limits specified by Intel are met. The gradual decrease in microprocessor voltage shown in both figures is controlled by the total capacitance. The larger the capacitance, the gentler the slope.

The simulation in Figure 1 shows the P55 microprocessor supply voltage drooping down to 2.42 V, even though the switching power supply has a 5-s response time. Since the voltage droops to 2.42 V and the P55 minimum supply voltage is 2.4 V, the converter must regulate to within  $\pm 20$  mV. This tolerance must accommodate variations in the feedback resistor divider, reference voltage, and minimum-to-maximum load regulation. If the converter's closed-loop bandwidth decreases to 20 kHz, the number of 100-F decoupling capacitors must increase from 6 to 24 to supply the transient current and keep the supply voltage at the specified level.

### AN719

The simulation shown in Figure 2 shows the P6 microprocessor supply voltage drooping down to 2.8 V, with the 100-kHz closed-loop bandwidth converter. Since the voltage droops to 2.8 V and the P6 minimum supply voltage is 2.755 V, the converter must regulate to within  $\pm 45$  mV. Just like the P55, the P6 requires an increase in the number of 100-F decoupling capacitors from 6 to 24, if the closed loop bandwidth is to decrease from 100 kHz to 20 kHz. A wide converter bandwidth is thus a mandatory feature, minimizing converter size

and cost, while meeting the power demands of these processors.

Previous SPICE simulation results for the P54 load transients correlated closely with the actual results as measured under laboratory conditions. We can thus expect that the P55 and P6 simulations will provide a very close approximation to the microprocessor's actual step response.

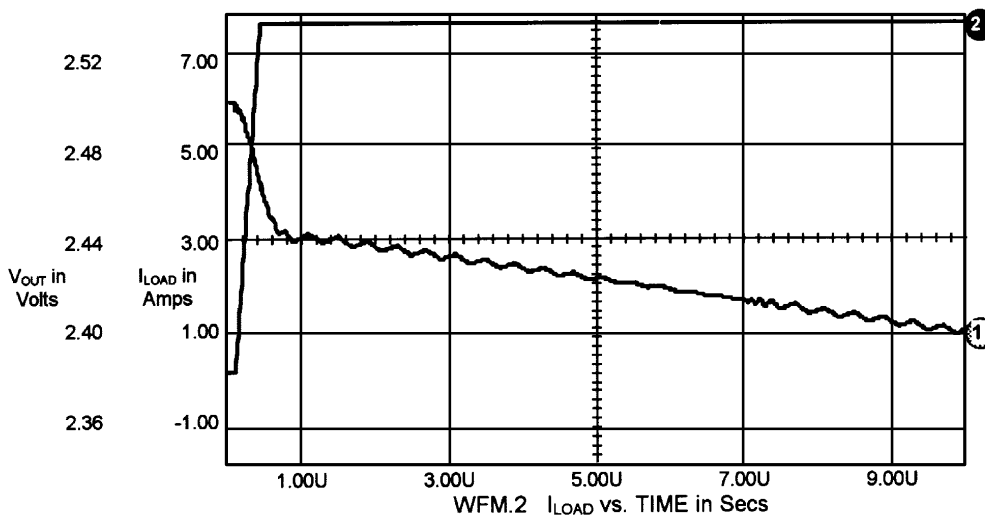

Figure 1. P55 Transient Load Simulation

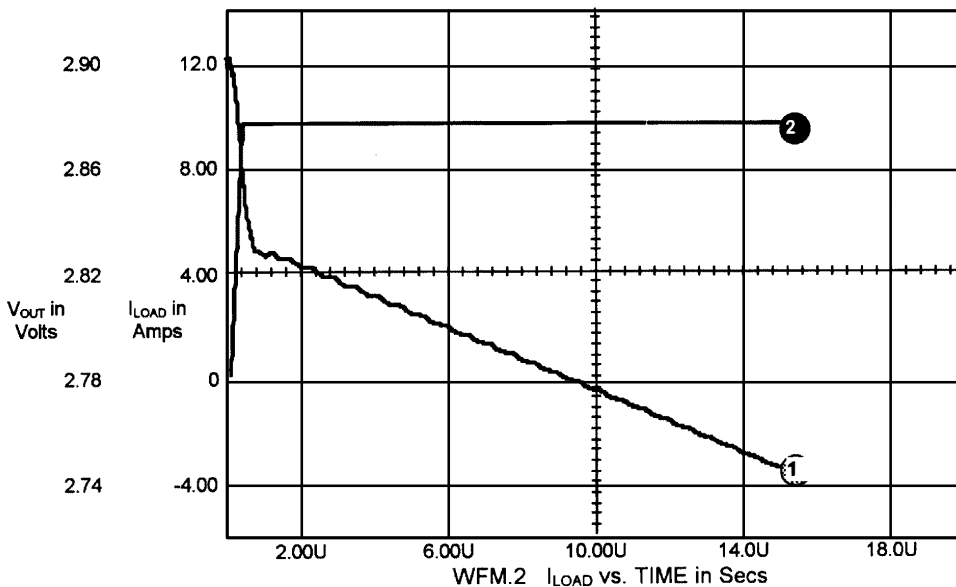

Figure 2. P6 Transient Load Simulation

### Choosing the Right Components

As noted above, the transient load demands of the P55 and P6 require the use of low-ESR capacitors for microprocessor decoupling and at the output of the power supply. Cost and space considerations dictate the use of either tantalum capacitors or Oscon organic aluminum capacitors with some ceramic capacitors.

The ceramic capacitors, which possess very low ESL and ESR values, provide the instantaneous current demands of the microprocessor. As shown in the SPICE simulations (Figures 1 and 2), the microprocessor's current is provided by the ceramic capacitors until the microprocessor voltage drops to the first knee. Since ceramic capacitors are relatively expensive, however, they should be used to handle this instantaneous current only.

During the gradual decrease in microprocessor voltage, current is supplied to the microprocessor by decoupling capacitors. This phase continues until the switching power supply responds to the increased demand for current. During this phase, the capacitors need to have low ESL and ESR values, but not quite as low as those of ceramic capacitors. The parasitic inductance of trace and lead length will delay the response time of the capacitors, so it is best to use surface-mount packages. The low-ESR TPS series of tantalum capacitors from AVX are a perfect fit for this application. Their surface-mount package minimizes lead inductance, while their low profile allows them to be placed directly beneath the microprocessor to cut down on parasitic trace inductance. (A minimum height of 0.123 inches is available between the bottom surface of the microprocessor package and the top of the printed circuit board.)

Oscon capacitors, with their high capacitance and low ESR-to-size ratio, are an ideal choice for the output of the switching power supply. With the high power conversion efficiency of Si9145 converter designs, power dissipation is minimized, keeping the temperature low and ensuring that the reliability of the Oscon capacitors is not compromised. Although TPS

series tantalum capacitors could be used, the price and lead-time for these parts have been rising dramatically since the introduction of the P54. As an alternative, Oscon capacitors will decrease the overall cost of the converter design.

When designing with the Si9145 for P55 and P6 applications, several simple adjustments must be made to handle the various loads. The number and value of input capacitors required to handle the specified output current are shown in Tables 1 and 2. These same tables show the recommended number of paralleled p- and n-channel Trench MOSFETs needed to meet the output current requirements of the P55 and P6. Finally, to maintain the 100-kHz converter bandwidth, the compensation network must be modified to accommodate the varying number and value of output and decoupling capacitances. Table 3 gives the feedback network component values for various combinations of these.

**Table 1: P55 Component Requirement**

<b>I<sub>O</sub> (A) Maximum</b>	<b>Quantity High-Side P-Channel Si4435DY</b>	<b>Quantity Low-Side N-Channel Si4410DY</b>	<b>Quantity Input (C1-C2) Capacitor Oscon-220 μF</b>
5.5A	1	1	1
8 A	2	1	2

**Table 2: P6 Component Requirement**

<b>I<sub>O</sub> (A) Maximum</b>	<b>Quantity High-Side P-Channel Si4435DY</b>	<b>Quantity Low-Side N-Channel Si4410DY</b>	<b>Quantity Input (C1-C3) Capacitor Oscon-220 μF</b>
5 A	1	1	1
8.5 A	2	1	2
10 A	2	2	2
14.5 A	3	2	3

**Table 3:** Feedback Network Component Values

Application	Total Output and Decoupling Capacitance	R11	C14	C8	C9	R4
P55	3 x 330 $\mu\text{F}^{\text{a}}$ . . . . . Oscon 6 x 100 $\mu\text{F}^{\text{b}}$ . . . . . Tantalum 25 x 1 $\mu\text{F}^{\text{b}}$ . . . . . Ceramic	10 k $\Omega$	220 pF	4.7 pF	150 pF	390 k $\Omega$
	4 x 330 $\mu\text{F}^{\text{a}}$ . . . . . Oscon 6 x 100 $\mu\text{F}^{\text{b}}$ . . . . . Tantalum 25 x 1 $\mu\text{F}^{\text{b}}$ . . . . . Ceramic	5.6 k $\Omega$	220 pF	4.7 pF	33 pF	510 k $\Omega$
P6	3 x 330 $\mu\text{F}^{\text{a}}$ . . . . . Oscon 6 x 100 $\mu\text{F}^{\text{b}}$ . . . . . Tantalum 25 x 1 $\mu\text{F}^{\text{b}}$ . . . . . Ceramic	10 k $\Omega$	220 pF	8.2 pF	150 pF	390 k $\Omega$
	4 x 330 $\mu\text{F}^{\text{a}}$ . . . . . Oscon 6 x 100 $\mu\text{F}^{\text{b}}$ . . . . . Tantalum 25 x 1 $\mu\text{F}^{\text{b}}$ . . . . . Ceramic	33 k $\Omega$	220 pF	4.7 pF	33 pF	510 k $\Omega$

a Power supply output capacitance.

b  $\mu$ processor decoupling capacitance.

## Sample Power Supply Designs

Optimal switching power supply designs using the Si9145 PWM IC, as shown in the schematics below, have been developed with the help of SPICE simulations for the P55 and P6:

- A P55 design with precision external reference, capable of handling a maximum 8-A output current (Figure 3)
- A P6 design, capable of handling 8.5 A of continuous output current (Figure 4)
- A 3.3-V logic supply design, capable of handling 5 A of output current (Figure 5)
- A 1.5-V GTL+ design, for a 5-A maximum output current (Figure 6)

A bill of materials and vendor supply list are also included for the designer's convenience.

## Conclusion

The Si9145 PWM controller, with its 400-kHz switching frequency, is the fastest available solution for P55 and P6 applications. Besides delivering speed, it reduces output capacitance with a 100-kHz closed-loop bandwidth, lowering the cost of the overall solution.

To obtain more information on designing switching power supplies that meet the demands of Pentium microprocessors, refer to Siliconix application note AN718, "Powering the Pentium CRE with the Si9145 Voltage Mode Controlled PWM Converter."

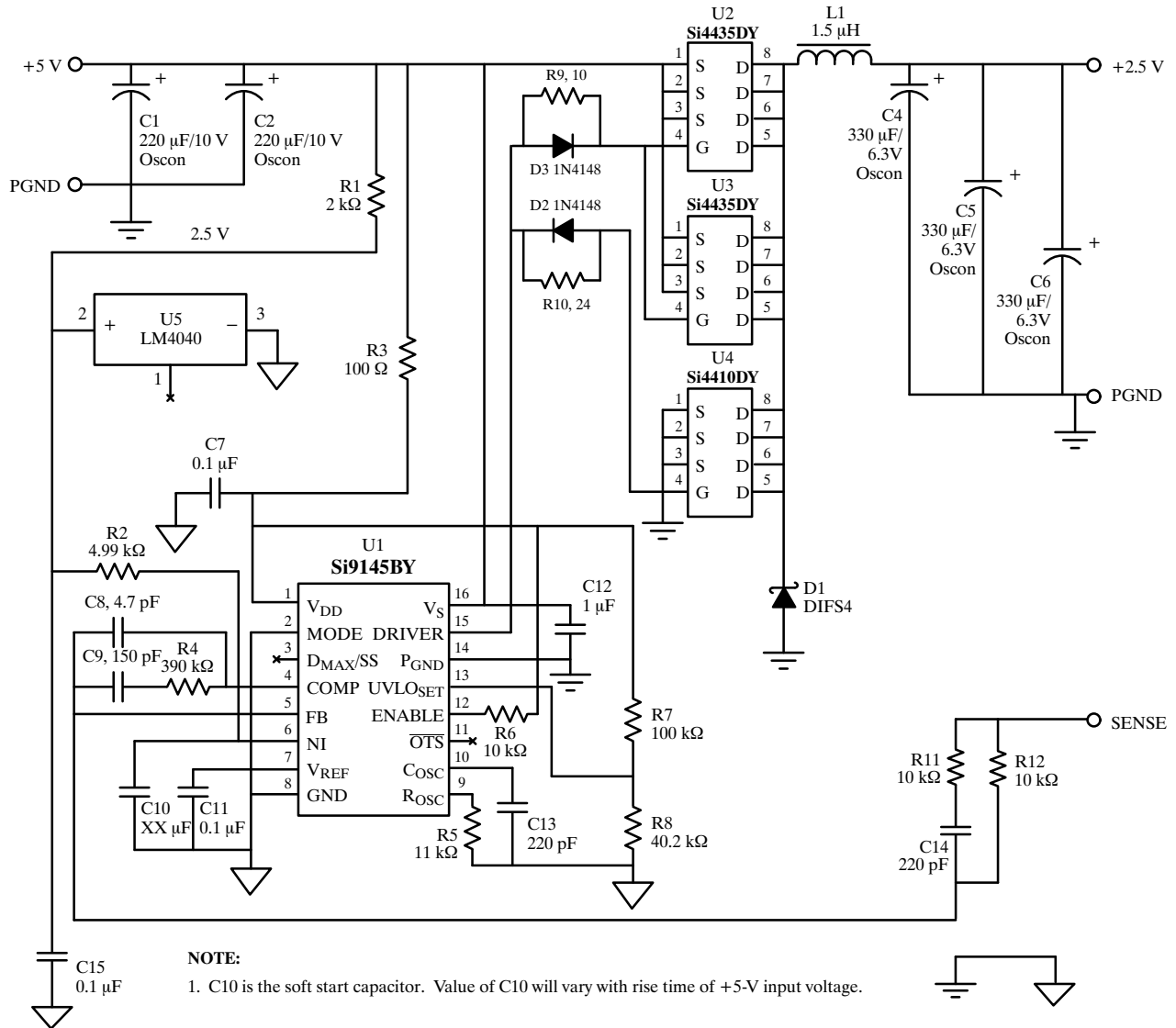

**Figure 3.** P55 Precision CPU Converter

### AN719

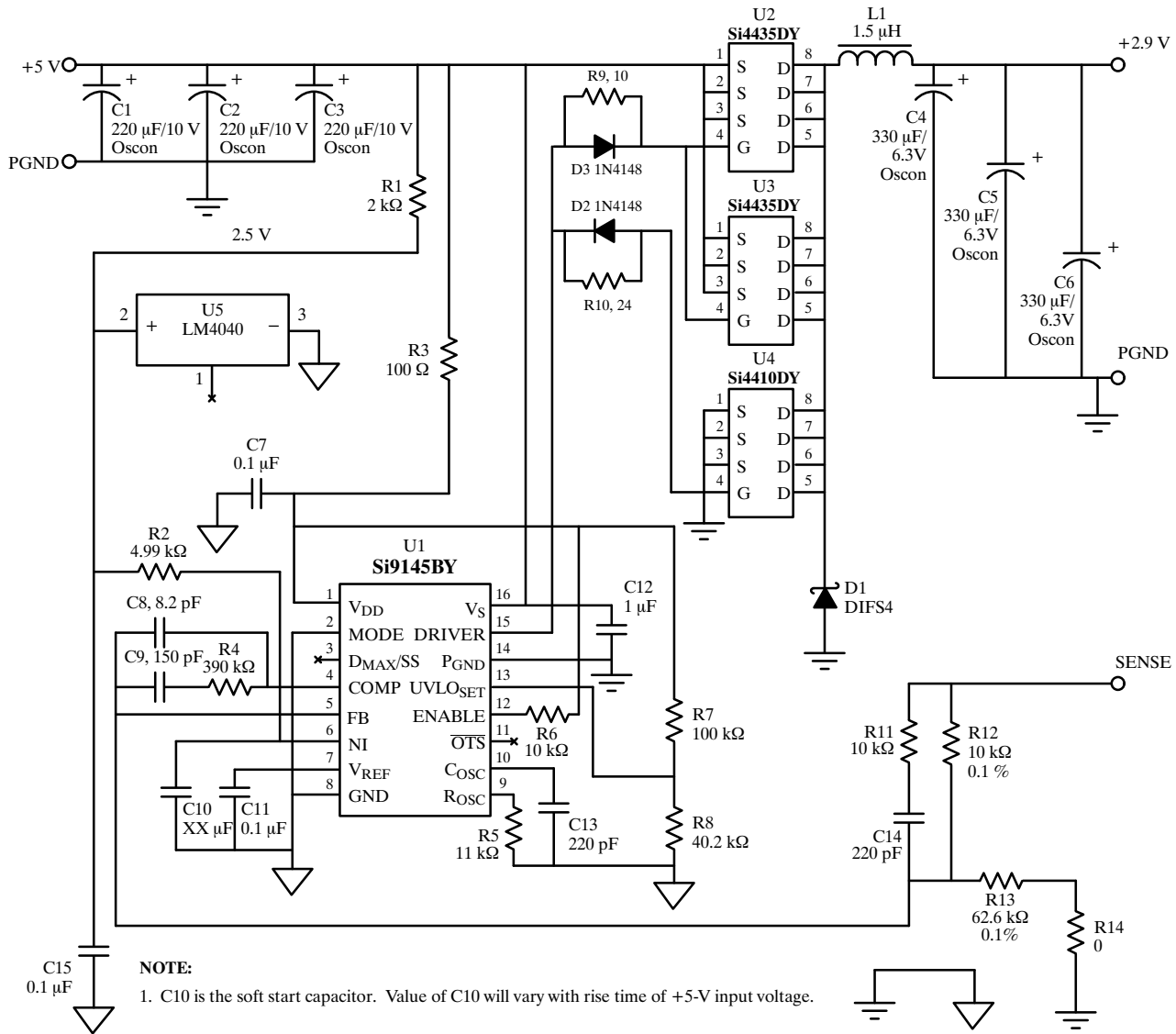

**Figure 4.** P6 Precision Converter

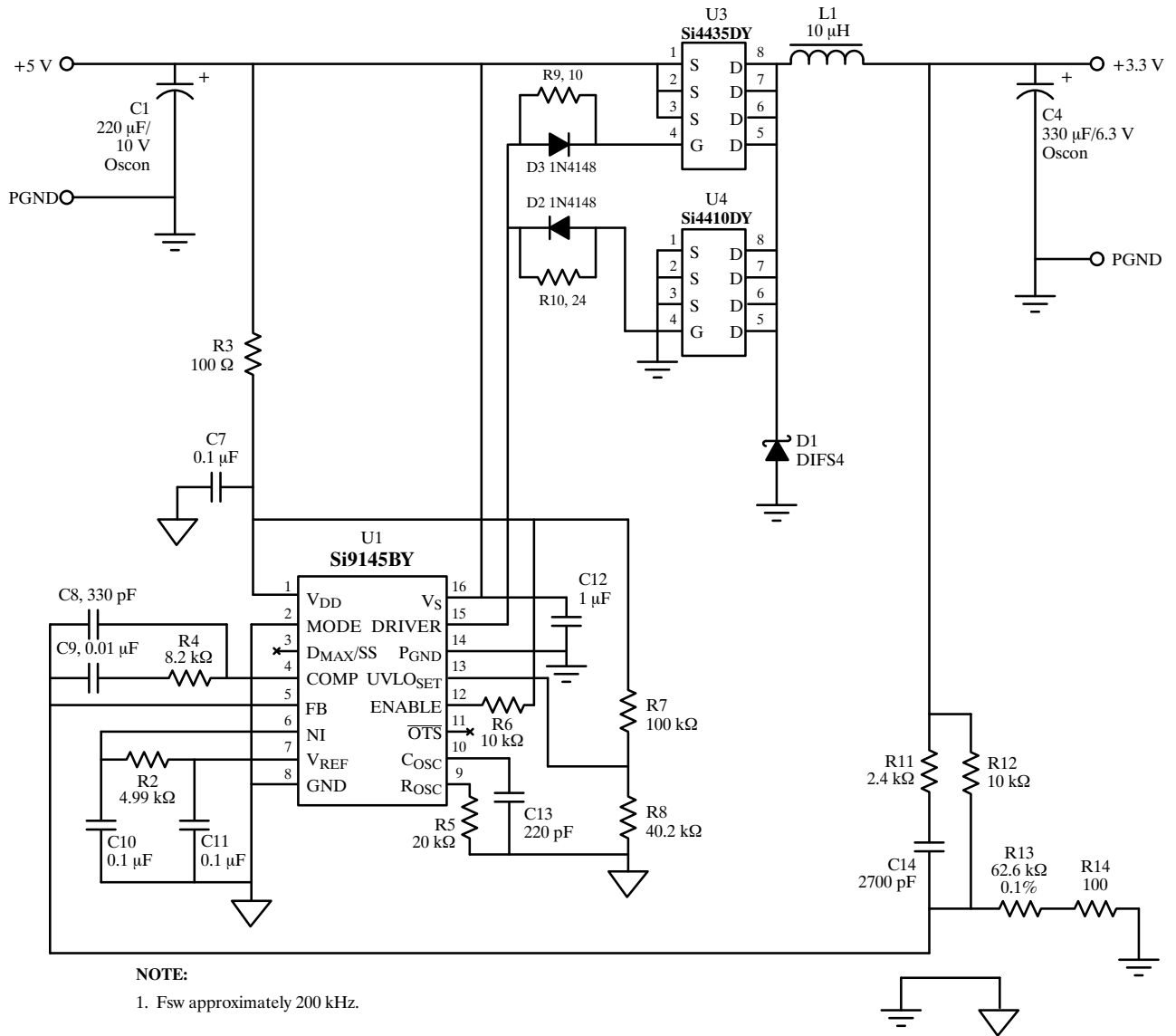

Figure 5. P6 3.3-V Converter

### AN719

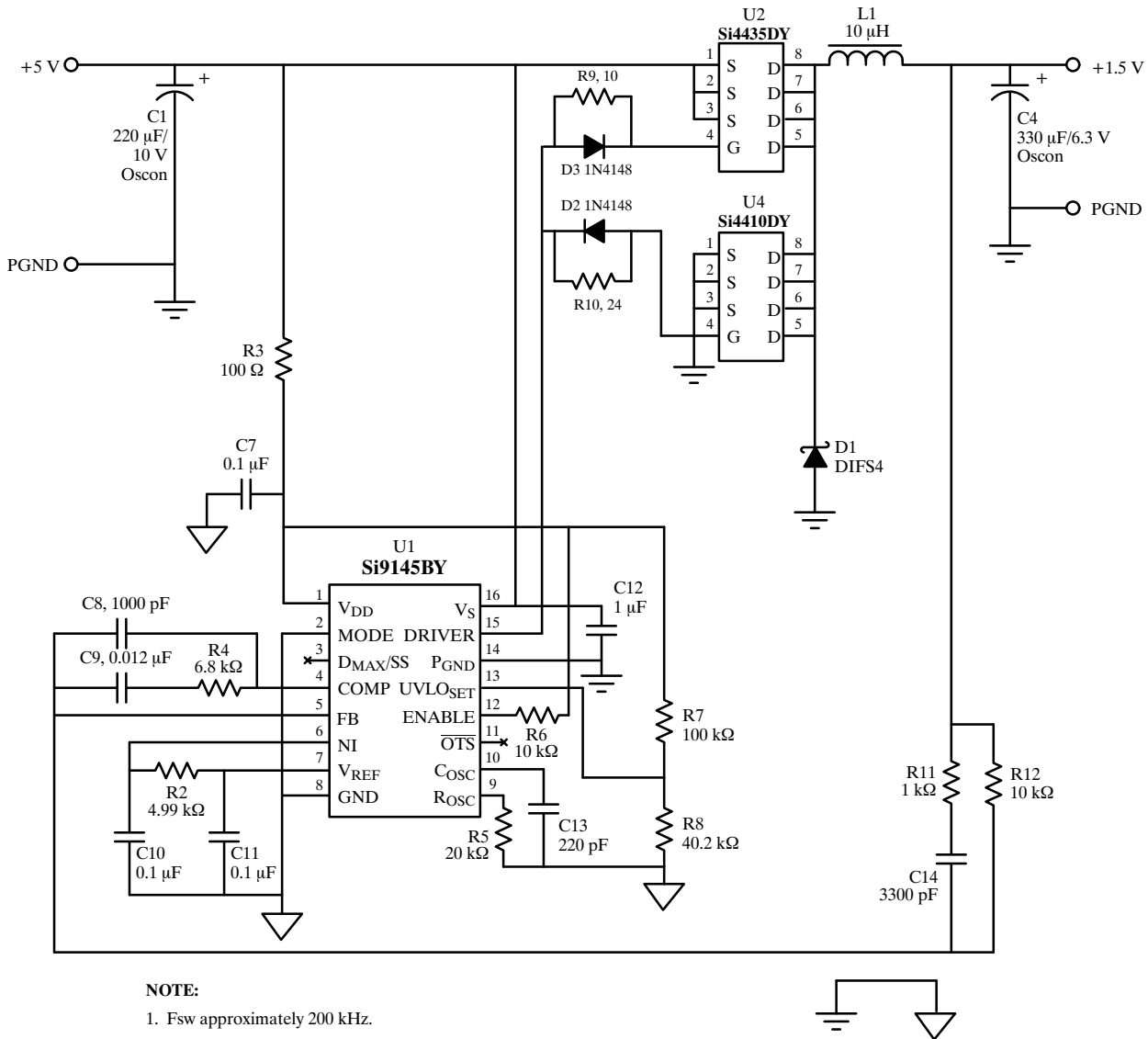

Figure 6. P6 GTL + Bus



## Attachment I Bill of Material for P55 CPU Converter

Part	Quantity	Part Type	Designators	Case Description
1	1	10 kΩ	R12	1206
2	3	0.1 μF	C7, C11, C15	0805
3	1	1.5 μH	L1	Inductor
4	2	1N4148	D2, D3	IF
5	1	1 μF	C12	1206
6	1	2 kΩ	R1	0805
7	1	4.99 kΩ	R2	0805
8	1	10	R9	0805
9	2	10 kΩ	R6, R11	0805
10	1	4.7 pF	C8	0805
11	1	11 kΩ	R5	1206
12	1	0	R14	0805
13	1	24	R10	0805
14	1	40.2 kΩ	R8	0805
15	1	390 kΩ	R4	0805
16	1	100	R3	0805
17	1	100 kΩ	R7	0805
18	2	220 pF	C13, C14	0805
19	2	220 μF/10 V	C1, C2	F
20	3	330 μF/6.3 V	C4, C5, C6	F
21	1	150 pF	C9	0805
22	1	D1FS4	D1	D-64
23	1	LM4040	U5	SOT-23
24	1	Si4410DY	U4	SO-8
25	2	Si4435DY	U2, U3	SO-8
26	1	Si9145BY	U1	SO-16
27	1	XX	C10	XX

**Attachment II**  
**Bill of Material for P6 CPU Converter**

Part	Quantity	Part Type	Designators	Case Description
1	1	10 kΩ 0.1%	R12	1206
2	3	0.1 μF	C7, C11, C15	0805
3	1	1.5 μH	L1	Inductor
4	2	1N4148	D2, D3	IF
5	1	1 μF	C12	1206
6	1	2 kΩ	R1	0805
7	1	4.99 kΩ	R2	0805
8	1	10	R9	0805
9	2	10 kΩ	R6, R11	0805
10	1	8.2 pF	C8	0805
11	1	11 kΩ	R5	1206
12	1	0	R14	0805
13	1	24	R10	0805
14	1	40.2 kΩ	R8	0805
15	1	62.6 kΩ 0.1%	R13	1206
16	1	390 kΩ	R4	0805
17	1	100	R3	0805
18	1	100 kΩ	R7	0805
19	2	220 pF	C13, C14	0805
20	3	220 μF/10 V	C1, C2, C3	F
21	3	330 μF/6.3 V	C4, C5, C6	F
22	1	150 pF	C9	0805
23	1	D1FS4	D1	D-64
24	1	LM4040	U5	SOT-23
25	1	Si4410DY	U4	SO-8
26	2	Si4435DY	U2, U3	SO-8
27	1	Si9145BY	U1	SO-16
28	1	XX	C10	XX

## Attachment III Bill of Material for P6 3.3-V Converter

Part	Quantity	Part Type	Designators	Case Description
1	1	10 k $\Omega$	R12	1206
2	3	0.1 $\mu$ F	C7, C11, C10	0805
3	1	10 $\mu$ H	L1	Inductor
4	2	1N4148	D2, D3	IF
5	1	1 $\mu$ F	C12	1206
6	1	2.4 k $\Omega$	R11	1206
7	1	4.99 k $\Omega$	R2	0805
8	1	10	R9	0805
9	1	10 k $\Omega$	R6	0805
10	1	330 pF	C8	0805
11	1	20 k $\Omega$	R5	1206
12	1	24	R10	0805
13	1	40.2 k $\Omega$	R8	0805
14	1	8.25 k $\Omega$	R13	1206
15	1	8.2 k $\Omega$	R4	0805
16	2	100	R3, R14	0805
18	2	220 pF	C13	0805
19	1	220 $\mu$ F/10 V	C1	F
20	1	330 $\mu$ F/6.3 V	C4	F
21	1	0.01 $\mu$ F	C9	0805
22	1	D1FS4	D1	D-64
23	1	Si4410DY	U4	SO-8
24	2	Si4435DY	U2, U3	SO-8
25	1	Si9145BY	U1	SO-16
26	1	2700 pF	C14	0805

**Attachment IV**  
**Bill of Material for P6 GTL+ (1.5-V) Converter**

Part	Quantity	Part Type	Designators	Case Description
1	1	10 k $\Omega$	R12	1206
2	3	0.1 $\mu$ F	C7, C11, C10	0805
3	1	10 $\mu$ H	L1	Inductor
4	2	1N4148	D2, D3	IF
5	1	1 $\mu$ F	C12	1206
6	1	1 k $\Omega$	R11	0805
7	1	4.99 k $\Omega$	R2	0805
8	1	10	R9	0805
9	1	10 k $\Omega$	R6	0805
10	1	1000 pF	C8	0805
11	1	20 k $\Omega$	R5	1206
12	1	24	R10	0805
13	1	40.2 k $\Omega$	R8	0805
14	1	6.8 k $\Omega$	R4	0805
15	1	100	R3	0805
16	1	100 k $\Omega$	R7	0805
17	1	220 pF	C13	0805
18	3	220 $\mu$ F/10 V	C1, C2, C3	F
19	3	330 $\mu$ F/6.3 V	C4, C5, C6	F
20	1	0.012 $\mu$ F	C9	0805
21	1	D1FS4	D1	D-64
22	1	Si4410DY	U4	SO-8
23	2	Si4435DY	U2, U3	SO-8
24	1	Si9145BY	U1	SO-16
25	1	3300 pF	C14	0805

## Attachment V Component Supplier List

Ref. Designator	Part Number	Description	Pattern	Vendor	Phone #
C1 – C6	6SA330M	Oscon	F	Sanyo	(619) 661-6835
	10SA220M	Capacitors			
D1	DIFS4	1.1 A, 40 V	IF	Shindeggen	(800) 543-6525
L1	CTX07-12877	1.5 $\mu$ H, 10 A	OD = 0.63", HT = 0.32"	Coiltronics	(407) 241-7876
	CTX10-5-KMLP	10 $\mu$ H, 5 A			
U1	Si9145BY	PWM IC	SO-16	Siliconix	(800) 554-5565
U2, U3	Si4435DY	P-Ch MOSFET	SO-8		
U4	Si4410DY	N-Ch MOSFET	SO-8		
U6	LM4040BIM	Reference	SOT-23	National	(408) 721-5000